

Ezy-Wash[®] CP Lead Safe[™] Powersoak Pre-Rinse Unit

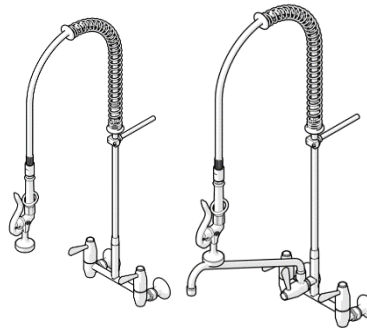

PRODUCTS					
Item Code	Description	WELS Rating	Water Consumption	Nominal Flow Rate	Outlet
181.14.38.00	Ezy-Wash CP Lead Safe [™] Powersoak Pre-Rinse Unit Standard	6	4.5	3.4	Trigger Spray
181.14.38.03	Ezy-Wash CP Lead Safe [™] Powersoak Pre-Rinse Unit with Pot Filler	*6	4.5	3.4	Trigger Spray & Pot Filler

***Components have a secondary outlet (pot filler) which is zero-star rated.**

SPECIFICATIONS
<ul style="list-style-type: none"> – Galvin Engineering recommends the installation of strainers and pressure reducing valves prior to installing the pre-rinse unit to ensure clean consistent water supply. Debris or poor water quality could cause the trigger to seize or fail to seal. – This pre-rinse unit has a 6 star WELS rating, the pot filler attachments are 0 star to allow fast pot filling. – Lead Safe[™] brass construction. *
<p>IMPORTANT: All Ezy-Wash[®] are tapware is tested in accordance with AS/NZS 3718 and leave our premises in good working order.</p>
<p>*Our Lead Safe[™] product range is compliant with the Lead Free Requirements of the NCC 2022 Vol. Three, Clause A5G4(2) and NSF/ANSI 372. **Any flow controller incorporated in the outlet to be tightened to prevent removal by hand. As Per AS3718.</p>
<p>WARNINGS: Special attentions to be paid on notes, photos, images, or drawings of assembly steps marked with the warning symbol.</p>



TECHNICAL DATA		
Inlet		G ½" - Female
Headworks		Jumper Valve
Working Pressure Range (kPa)	Min	100
	Max	500
Working Temperature Range (°C)	Min	5
	Max	65
Finish		Chrome

NOTE: Galvin Engineering continually strives to improve their products. Specifications may change without notice.

TOOLS REQUIRED

- Adjustable spanner
- Hex key
- Power drill
- Thread tape / sealant

PRE-INSTALLATION

Wall Spud

- This model is a dual inlet unit requiring two wall spuds. Spuds must be G 1/2" MI, 205 apart and protrude from the finished wall by no more than 15mm.

Wall Bracket:

- Mark out the three (2) holes for mounting the wall bracket assembly at a height of 400mm. Drill as shown in the image. (Supplied fasteners may not be suitable for the mounting surface. If this is the case, suitable fasteners will need to be sourced by the installer)

! Note: We recommend the wall bracket is installed at 400mm. The wall bracket can be mounted lower. However, the further it is mounted away from the circlip, the more the stability of the unit is compromised.

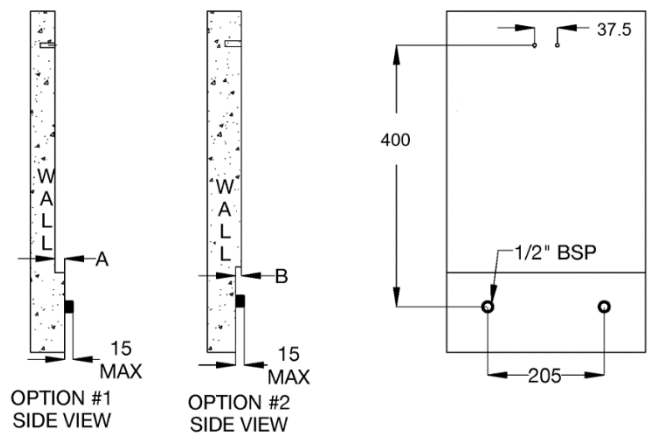

! MOUNTING DETAILS

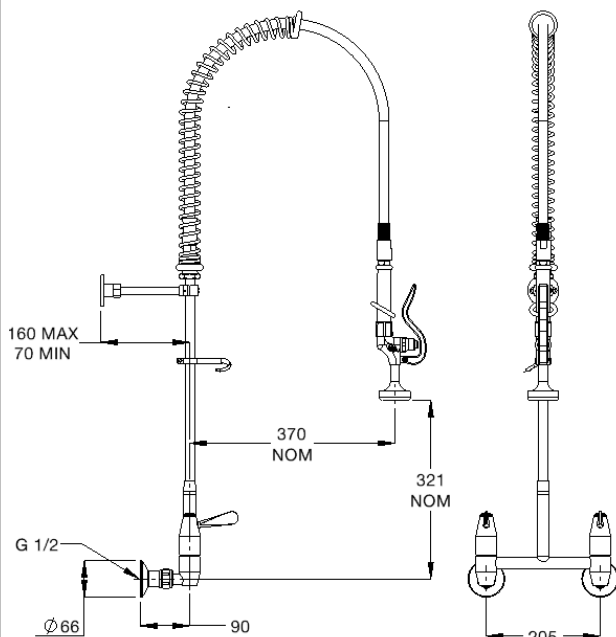

181.14.38.00

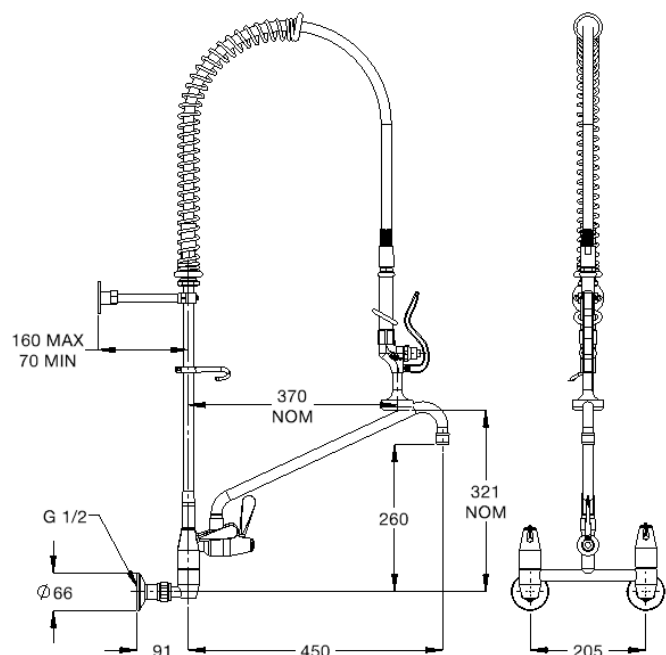

181.14.38.03

INSTALLATION

INSTALLATION COMPLIANCE: Galvin Engineering products must be installed in accordance with these installation instructions and in accordance with AS/NZS 3500, the PCA and your local regulatory requirements. Water and/or electrical supply conditions must also comply to the applicable national and/or state standards. Failing to comply with these provisions shall void the product warranty and may affect the performance of the product.

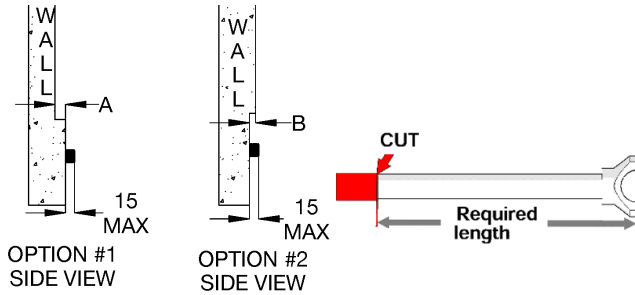

1. Measure and cut support rod

- Choose the appropriate option, as shown above, then measure distance 'A' or 'B'.
- Required support rod length (Option #1) = $X + A$.
- Required support length (Option #2) = $X - B$.
- $X = 70\text{mm Min}$
- If the wall is flush, $A = B = \text{zero}$. Therefore, cut the support rod at 70mm Min .
- Cut the support rod accordingly; ensure the threaded end is **NOT** cut off.

! Note: Distance B cannot be greater than 17mm. If distance "A" is greater than 145mm, then an extension support rod must be purchased.

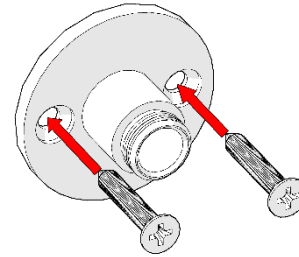

2. Fit wall bracket

- Secure the wall bracket to the wall. Supplied fasteners may not be suitable for the mounting surface. If this is the case, suitable fasteners will need to be sourced.

! Note: The wall bracket must be mounted with two screws for stability and strength. This is critical and failure to do this may void the warranty.

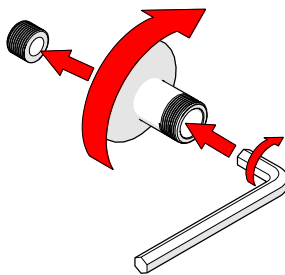

3. Fit body flange

- Fit the body flanges to wall spud. Use thread tape or equivalent to ensure the connection does not leak.

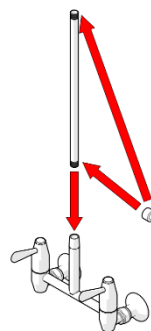

181.14.38.00

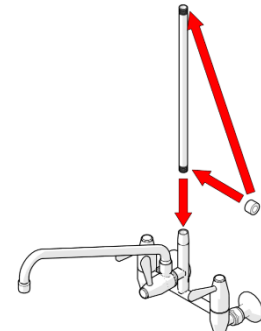

181.14.38.03

4. Fit pre-rinse riser

- If pot filler kit (181.14.38.03) has been purchased, it must be attached to the pre-rinse unit prior to fitting the riser to the body. Apply thread tape to the end of the short riser and fit into mixer body and tighten, ensuring correct orientation.
- Standard pre-rinse (181.14.38.00) - apply thread tape to both ends of the riser and fit into the mixer body and tighten.

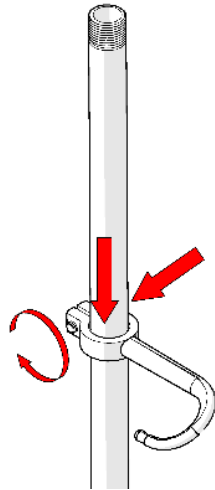

5. Fit hook to riser (as shown)

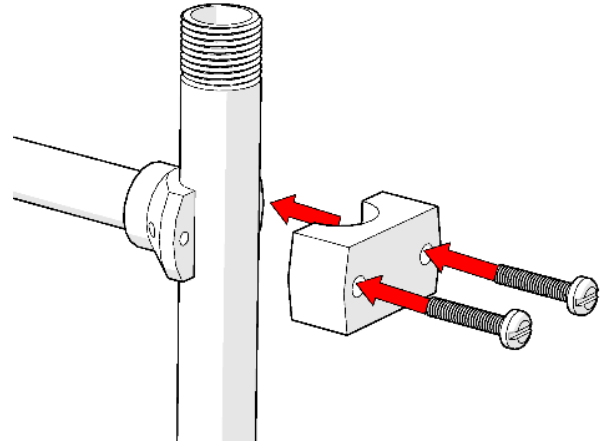

6. Fit support rod

- If pot filler kit (181.10.38.03) has been purchased, it must be attached to the pre-rinse unit prior to fitting the support rod to the riser. Refer to the installation instruction supplied with the pot filler.
- Screw support rod into the riser hook and ensure it is not fully tightened.

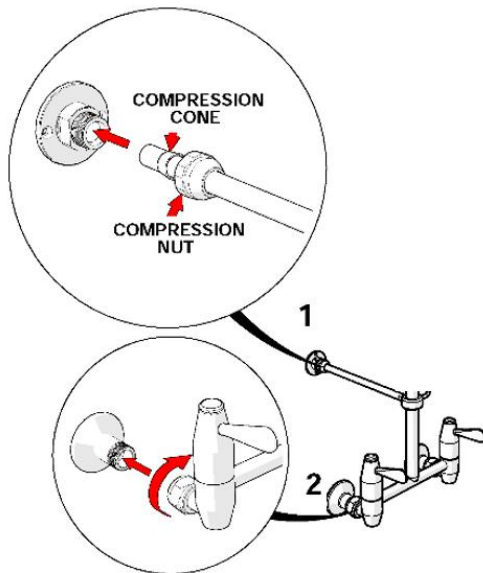

7. Fit pre-rinse riser assembly

1. Fit compression nut to support rod, followed by the compression cone and locate the support rod into wall bracket.
2. Fit the pre-rinse riser assembly to fitted body flange. Ensure the sealing o-ring is inside the loose nut.

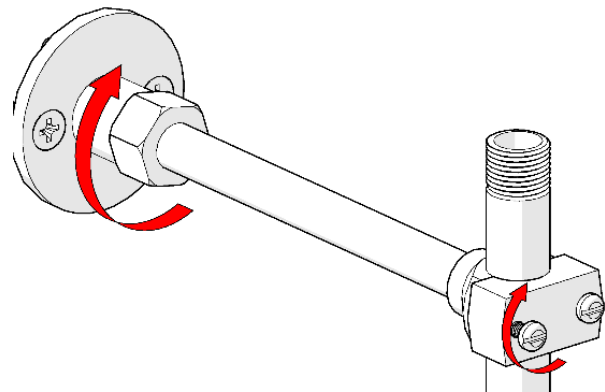

8. Secure support rod

- Fasten support rod securely against CP riser.
- Tighten compression nut on wall bracket to secure the support rod. The rod is now rigid.

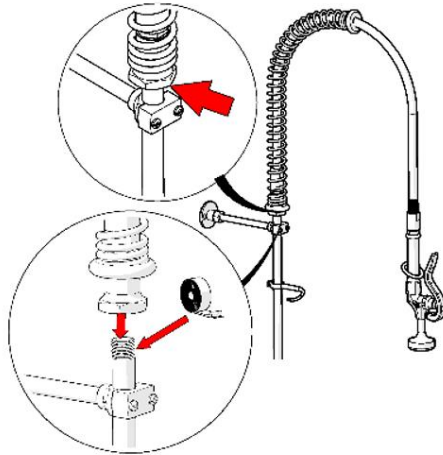

9. Fit hose

- Fit hose to the pre-rinse riser with a spanner, ensure apply thread tape the riser.

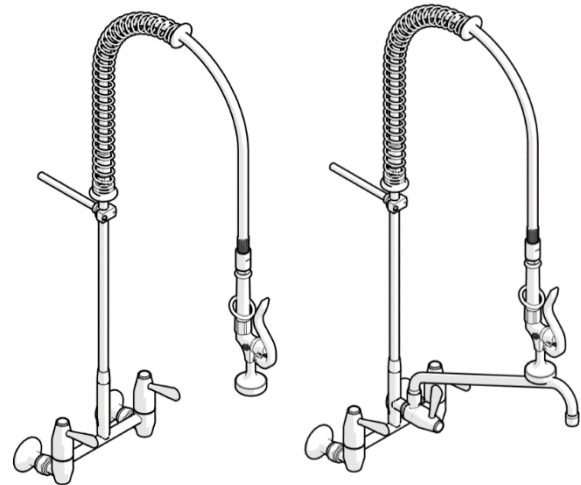

181.14.38.00

181.14.38.03

10. Test unit

- Once all fittings have been tightened securely, connect the unit to the mains water.
- Turn on water and test the unit for any leaks.

WARNINGS

- ⚠ For optimum performance it is recommended that the isolation or mains taps are turned off whilst the unit is not in use (overnight etc.), so that the unit is not under mains pressure when unsupervised. Flood damage may occur if a failure occurs whilst the unit is under mains pressure (warranty is void in this instance).
- ⚠ Galvin Engineering recommends that the handpiece is periodically serviced by a qualified plumber.
- ⚠ **IMPORTANT:**
To seal the hose this unit uses Loctite 577 which is a thread sealant approved for use with potable water (AS/NZS 4020). If hose is to be removed for maintainance purposes, reseal the joints with Loctite 577, or an equivalent sealant compliant with AS/NZS 4020. Do not use thread tape to seal the hose connections, as this may cause the hose nut to become loosened over time and leak.

WARRANTY

Galvin Engineering products are covered under our Manufacturer's Warranty. Galvin Engineering products must be installed in accordance with the installation instructions and in accordance with AS 3500 and NCC Volume Three, relevant Australian Standards and local authorities applicable to product being installed. Water and electrical supply conditions must also comply to the applicable national and/or state standards, failing to comply with these provisions may void the product warranty and affect performance of the product.

Please visit www.galvinengineering.com.au to view the full warranty, our Installation Compliance and Maintenance & Cleaning information as well as any other additional information.

Within Australia: **1300 514 074** Outside Australia: P: **+61 (0)8 9338 2344**

F: **+61 (0)8 9338 2340**

sales@galvinengineering.com.au

www.galvinengineering.com.au

ABN: 78 008 719 382

PERTH | SYDNEY | MELBOURNE | BRISBANE | ADELAIDE

